

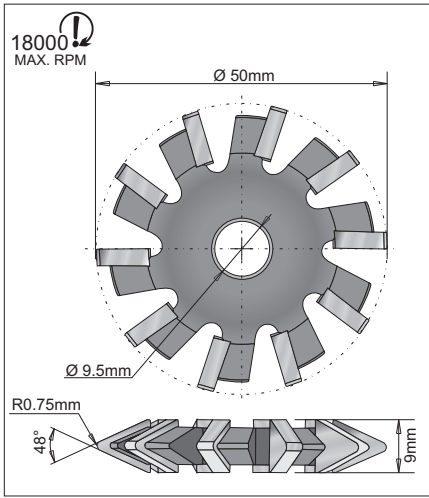

**Cutter-50**  Category

The carbide tipped Cutter-50 is used by many of our customers in the metal industry:



Tool no.	Dia	R	Teeth	Thick	Bore
Cutter-50	50mm	0.75mm	10	9mm	9.5mm

**Application example:**

Using an electric or pneumatic DIE Grinder, stainless steel or aluminum tank trailers for the transportation of cheical products, food, dry bulk, crude oil, ethanol, vacuum tamnkers, hot products...

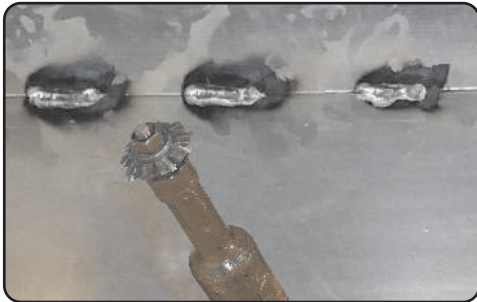

Spot welds: shear off sharp and excess material caused by the molten after brazing or soldering (prior to the finished weld) with a hand-held rotary tool.



"V"grooves: cut "V"grooves into 2 pieces of metal butt up against each other with a hand-held rotary tool (strengthens the bond between the base metal and the molten material during brazing or soldering)



Finished welds: shear off sharp and excess molten material caused by the molten after brazing or soldering (cleaner finished weld) with a hand-held rotary tool.

